



INTERNATIONAL JOURNAL OF ADVANCE RESEARCH, IDEAS AND INNOVATIONS IN TECHNOLOGY

ISSN: 2454-132X

Impact factor: 4.295

(Volume 5, Issue 3)

Available online at: www.ijariit.com

Smart walking stick for blind people

Puja Dattatraya Chavan

pujachavan1303@gmail.com

SVPM 's College of Engineering, Malegaon, Maharashtra

Borate Sukeshkumar Pandurang

sukesh.borate@gmail.com

SVPM 's College of Engineering, Malegaon, Maharashtra

ABSTRACT

Blind people generally use the typical white cane. Movability for the visually impaired person is a huge problem. In this paper, we propose a safe path to blind people using a microcontroller, ultrasonic sensor, GPS, GSM, speaker to make the smart stick. obstacles continuously detected using the ultrasonic sensor, depends on it voice message will be playing like take left, stop, take right, etc. and also detect location.

Keywords— Microcontroller, GPS, GSM, Speaker, Ultrasonic sensor

1. INTRODUCTION

The eyes play an important role in our life. India is now home to 15 million blind population. 285 million people are visually impaired in the world. While India needs 40,000 ophthalmologists. It has only 8,000. The smart stick is used the ultrasonic sensor for obstacle detection. In case something happens and the blind person lost somewhere then we can use push button when pressed then automatically GPS will detect the location and send it to the controller.

2. REVIEW

The sonic torch is battery operated and is about the size of a large electric torch. mowat sensor is a light weight, hand held. Pocket size device and is quite similar to a common torch that is used by the sighted people. This navigation system will guide the visually impaired person along the path by providing audio navigation assistance to reach the desired destination. To avoid collision ultrasonic sensor will be interfaced with the Raspberry Pi [1].

In this paper, a smart Electronic Traveling Aid (ETA) called BlinDar has been proposed. This smart guiding ETA ameliorates the life of blind as it is well equipped with Internet of Things [2]. The stick is able to detect static and dynamic obstacles of any height which are in front of the person. [3]

A stick guide model represented for a blind person to guide in their way, which consist of a global positioning system and global system for mobile communication modules. [4] Stick solution use different technologies like ultrasonic, infrared and laser. [5]

Blind people need to improve both orientation and movability capabilities in order to be able to walk autonomously and safely using a white cane [6]. The sensor system comprises of three ultrasonic sensors to acquire obstacle distance measurements and the user can interpret the distance information as a tactile sensation[7].

3. PROPOSED SYSTEM

Figure 1 shows the proposed system block diagram the smart stick designed. the connection is simple and the configuration is done automatically.

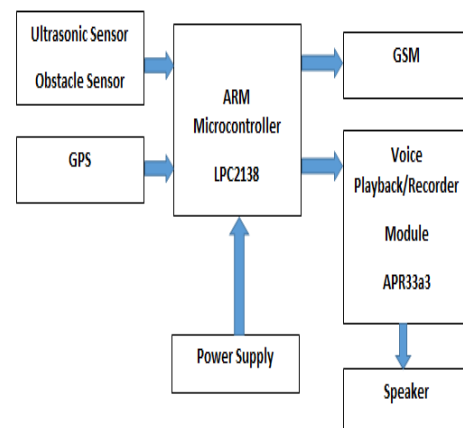

Fig. 1: Block diagram of the proposed system

3.1 Microcontroller

The LPC2138 microcontrollers are based on a 32-bit ARM7TDMI-S CPU. Microcontrollers is real-time Rivalry and embedded trace support, that combine the microcontroller with 32 kB, 64 kB, 128 kB, 256 kB and 512 kB of embedded high-speed flash memory.

Due to their small size and low power usage, these microcontrollers are model for applications where miniaturization is a key requirement, such as access control and point-of-sale. Microcontroller range is a wide of serial communications interfaces and on-chip SRAM options of 8 kB, 16 kB, and 32 kB, they are very well suited for communication gateways and protocol converters, soft modems, voice recognition and low-end imaging, providing both large buffer size and high processing power.

3.2 GPS

GPS (Global Positioning System) is a system that receives the electric wave from the GPS satellite that turns round the earth and calculates the position based on it. Therefore, the application to the measurement business is widely done, and the model that applies the GPS function to the mobile phone has extended. The Global Positioning System (GPS) is a network of 24 satellites, maintained by the US military forces, that provides information about a person's location almost anywhere in the world when navigating outdoors. GPS-based navigation systems are an orientation aid, as the satellites provide constantly updated position information whether or not the footer is moving. When in motion, the software uses the sequence of GPS signals to also provide main information.

3.3 GSM

GSM (A Global System for Mobile communication) module is a specialized type of module which accepts a SIM (Subscriber Identity Module) card and operates over a subscription to a mobile operator. When a GSM module is connected to a microcontroller, this allows the microcontroller to use the GSM module to communicate over the mobile network. A GSM module to get pressed an interface that allows applications to send and receive messages over the module interface. To perform these tasks, a GSM module must support an "extended AT command set" for sending/receiving SMS messages.

3.4 Ultrasonic Sensor

The sonar system is based on two ultrasonic sensors mounted together. One sensor emits an ultrasonic wave while the other measures the echo. By differentiation of the input and output signals, the PIC 16F876 computes the distance to the nearest obstacle. Then this information is transmitted as a Pulse Wide Modulation (PWM) signal to the receiver. The ultrasonic module used as a sensor for this application is the MSU10 from 'Lextronic' and can be seen in the figure. It has an angle of detection of 720.

Ultrasonic sensor ranging module HC - SR04 provides 2cm – 4m non-contact measurement function. The sensor ranging accuracy can reach to 3mm. The ultrasonic modules include ultrasonic transmitters, receiver and control circuit.

4. CONCLUSION

This paper describes the microcontroller based smart walking stick using the ultrasonic sensor. It can send and receive data from mobile devices. The design of the blind stick efficiently with low power rechargeable battery. It can help the visual impaired person appreciably in guiding in their way.

5. REFERENCES

- [1] Madhura Gharat, Rizwan Patanwala, Adithi Ganaparthi "Audio guidance system for blind", International Conference on Electronics, Communication and Aerospace Technology ICECA 2017.
- [2] Zeeshan Saquib, Vishakha Murari, Suhas N Bhargav, "BlinDar: An Invisible Eye for the Blind People", 2017 2 IEEE On Recent Trends In Electronics Information & Communication Technology, May 19-20, 2017, India.
- [3] Sharang Sharma, Manind Gupta, Amit Kumar "Multiple Distance Sensors Based Smart Stick for Visually Impaired People", 978-1-5090-4228-9/17/\$31.00 ©2017 IEEE.
- [4] Kunja Bihariswain, Rakesh kumar patnaik, suchandra pal "Arduino based automated stick guide for a visually impaired person", 2017 international conference on smart technologies and management or computing communication, controls, energy and materials (ICSTM). VeltechDr.RR& Dr.SR University Chennai, T.N India 2-4 august 2017.pp407-410.
- [5] Ayat A. Nada, Mahmoud A. Fakh, Ahmed F. Seddik "Assistive Infrared Sensor Based Smart Stick for Blind People Science and Information Conference 2015 July 28-30, 2015 | London, UK".
- [6] M. Yusro¹, 3, K.M. Hou¹, E. Pissaloux², H.L. Shi¹, K. Ramli³ and D. Sudiana³ "SEES: Concept and Design of a Smart Environment Explorer Stick" Sopot, Poland, June 06-08, 2013.
- [7] M. P. Menikdiwela¹, K.M.I.S.Dharmasena², A.M. Harsha S. Abeykoon³ "Haptic based walking stick for visually impaired People" Department of Electrical Engineering, University of Moratuwa Katubedda, Moratuwa, Sri Lanka 'IEEE2013.